



WanderGuard[®] ID Departure Alert System Model 16921

The WanderGuard ID departure alert system features advanced electronics for enhanced system performance. A host of models and options help you design and customize a system that meets your requirements and budget, with the quality offered by the WanderGuard name.

The WanderGuard ID System installs easily for use on single and double doors, hallways and elevators. **The patented Pre-Alert[™] technology helps monitor elopements BEFORE they occur.**

The system allows for simple system upgrade and expandability as your facility grows.

Nationwide Field Service

Our fleet of Field Support Representatives are company employees providing professional on-site installation and service.

Standard Features

- ▲ Resident ID on System Status Display
- ▲ Pre-Alert[™] detection alarms
- ▲ Intelligent interference detection system
- ▲ Continuous self-test operation
- ▲ Power failure alert
- ▲ Bracelet replace notification
- ▲ WanderGuard Bracelet Manager Software
- ▲ Programmable keypad option
 - Alarm mode and timed bypass with audio and visual countdown
 - Selective and non-selective modes
 - 4 programmable alarm tones
- ▲ System Status Display with intuitive user interface

Options and Accessories

- ▲ Patented Pre-Alert[™] remote annunciator
- ▲ Wired & wireless remote annunciators
- ▲ Selective locking available with WanderGuard locks
- ▲ Integrates with Arial[®] wireless communication system
- ▲ WanderGuard Easy Programmer for ID bracelets
- ▲ Universal Tester door alarm and signaling device tester

Specifications

- ▲ Receiver dimensions: 8.5" x 4.25" x 1.75"
- ▲ Antenna dimensions: 6.4" x 4.5" x 2.75"
- ▲ System Status dimensions: 4.5" x 5.5" x 1.5"
- ▲ Receiver weight: 2 lbs
- ▲ Antenna weight: 1.5 lbs
- ▲ System Status weight: .5 lbs

STANLEY[®]

Healthcare Solutions

Toll-Free: 800-824-4494

Office: 402-475-4002

Fax: 402-475-4281

www.stanleyhealthcare.com

Recessed Single Door Application

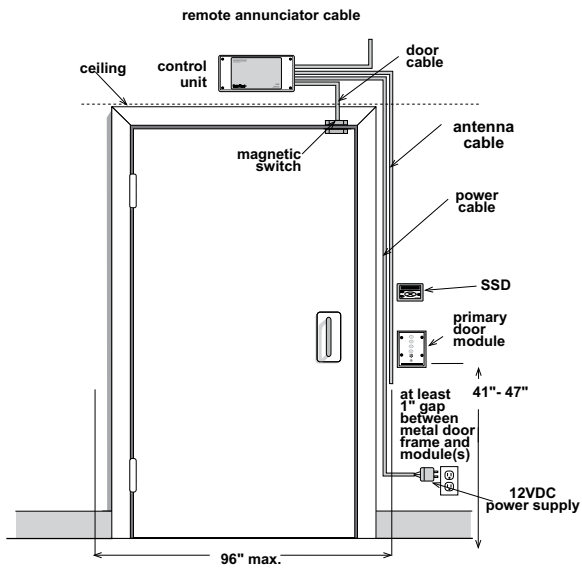

Recessed Double Door Application

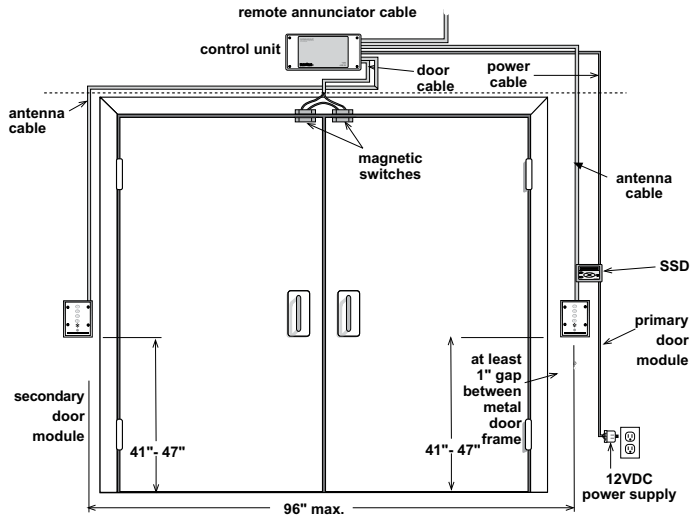

Elevator Entrance with Passive Infrared Sensor

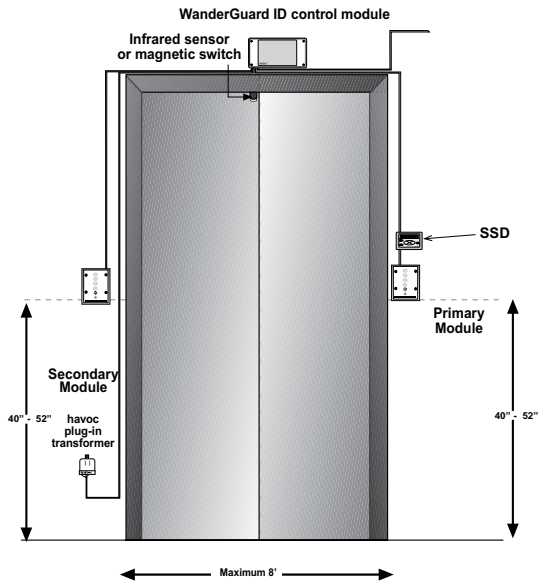

Hallway Application with Passive Infrared Sensor

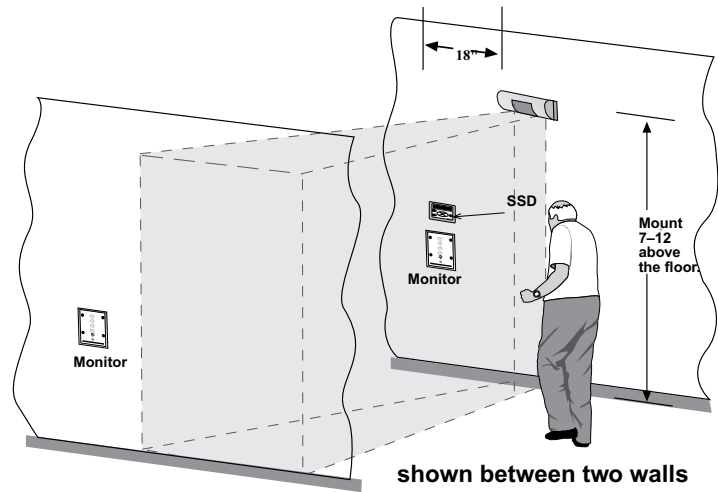

Specifications

Receiver dimensions: 8.5" x 4.25" x 1.75"

Antenna dimensions: 6.4" x 4.5" x 275"

System Status dimensions: 4.5" x 5.5" x 1.5"

Receiver weight: 2 lbs

Antenna weight: 1.5 lbs

System Status weight: .5 lbs

Electrical requirements: 120 VAC

Audible alarm: Approximately 80 decibels at 36"